



戶外裝備101，淺談個人裝備

戶外安全對策本部 洪維忼



講師簡歷

(洪維忼 ROBERT)

- 學歷：

- 國立中興大學 生物產業機電工程系學士
- 國立臺灣師範大學 公民教育與活動領導學系 碩士
- 英國Coventry University 博士班，專攻野外緊急醫療救護
- 美國戶外領導學校 (NOLS) 戶外教育者結訓



現職

- 戶外安全對策本部 本部長
- 美國Leave No Trace Ethic Center Master Educator
- 台北市政府義勇消防總隊救護大隊建成分隊 隊員
- 台北市政府義勇特搜隊 救援組小組長
- 台灣傳統射箭學會 理事、丙（C）級教練
- 台北醫學院、旺英衛教基金會 緊急救護課程指導員
- 台北市雙溪國小山林冒險體驗活動 合作教練
- ISO 29990（非正規教育及學習服務品質管理系統認證）內部稽核員



請寫下「令人愉快的露營」的定義



GORE-TEX 的衣服代表可以保暖？



最好的戶外用鞋就是登山鞋



參加童軍大露營活動就應該要帶行李箱



沒有最好的裝備

只有最合適的裝備







- 衣：頭、頸、軀幹、上肢、下肢
- 食：炊具、鍋具、餐具、打火機/火柴/鎂塊、水壺/保溫瓶
- 住：帳篷、睡墊、睡袋、防潮布
- 行：襪子、鞋子、登山杖、地圖、指北針、照明、背包
- 育樂：工具、急救包

照明系統

保護系統



導航系統

保暖系統

工具系統

救命系統

備用食物 

備用飲水 



住宿系統

升火工具 



乾 爽 濕 冷

衣

- 頭部：遮陽帽、保暖帽
- 頸部：圍巾、圍脖
- 軀幹：內衣、外衣、保暖衣、雨衣
- 上肢：保暖手套、防水手套
- 下肢：內褲、外褲、雨褲



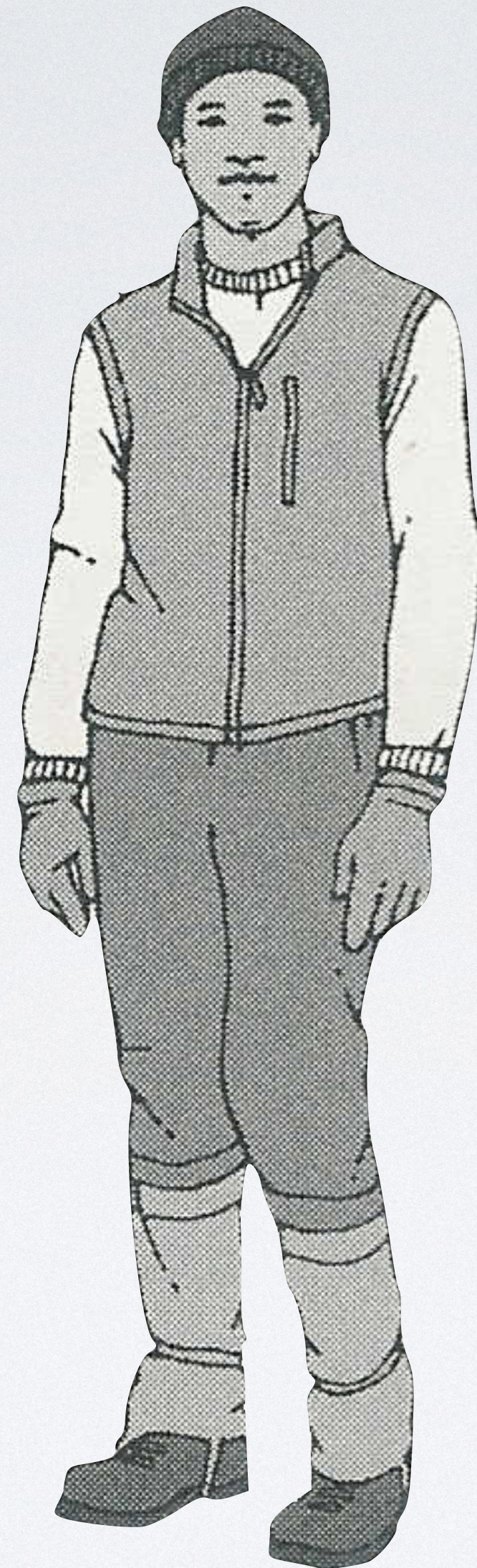
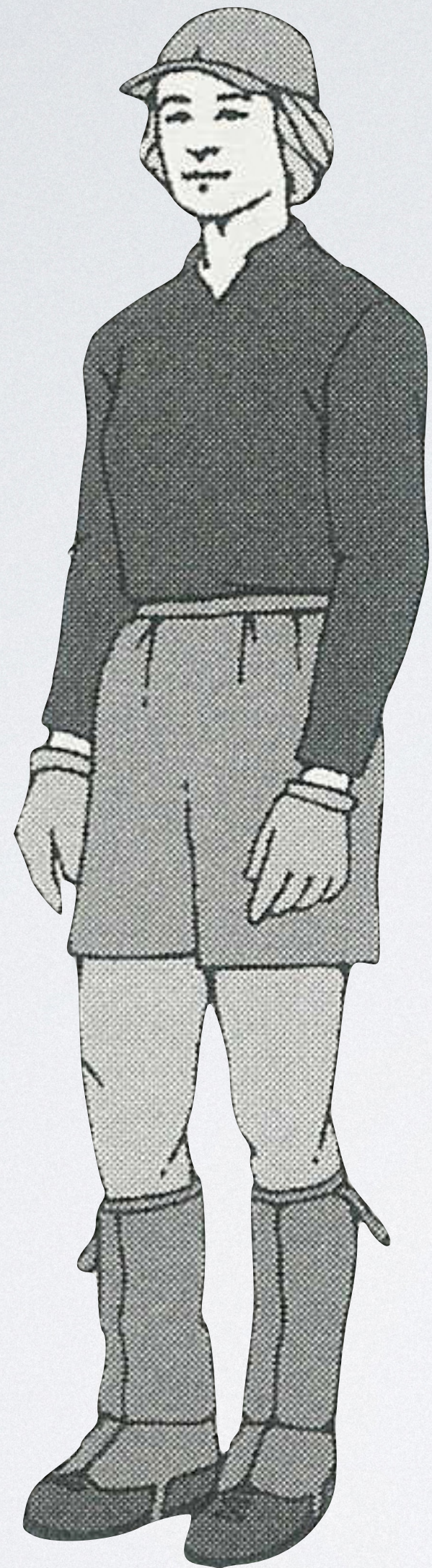
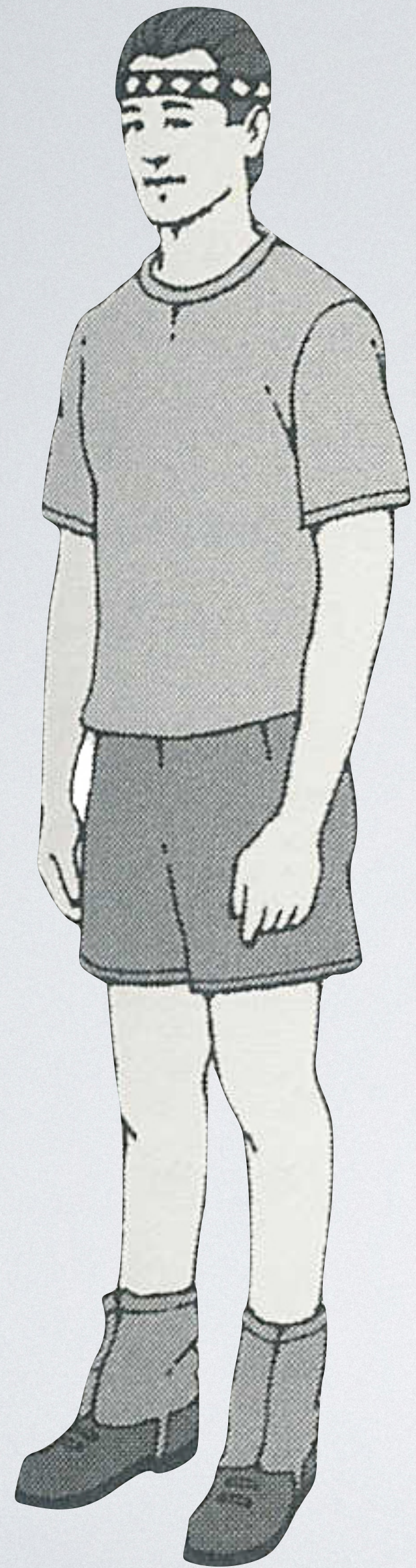

食

- 炊具：固體燃料、液體燃料、氣體燃料
- 鍋具：煮鍋、煎鍋
- 餐具：碗、筷、湯匙、叉子
- 火：打火機、火柴、鎂塊
- 水：水壺、水袋、吸管水袋、保溫瓶

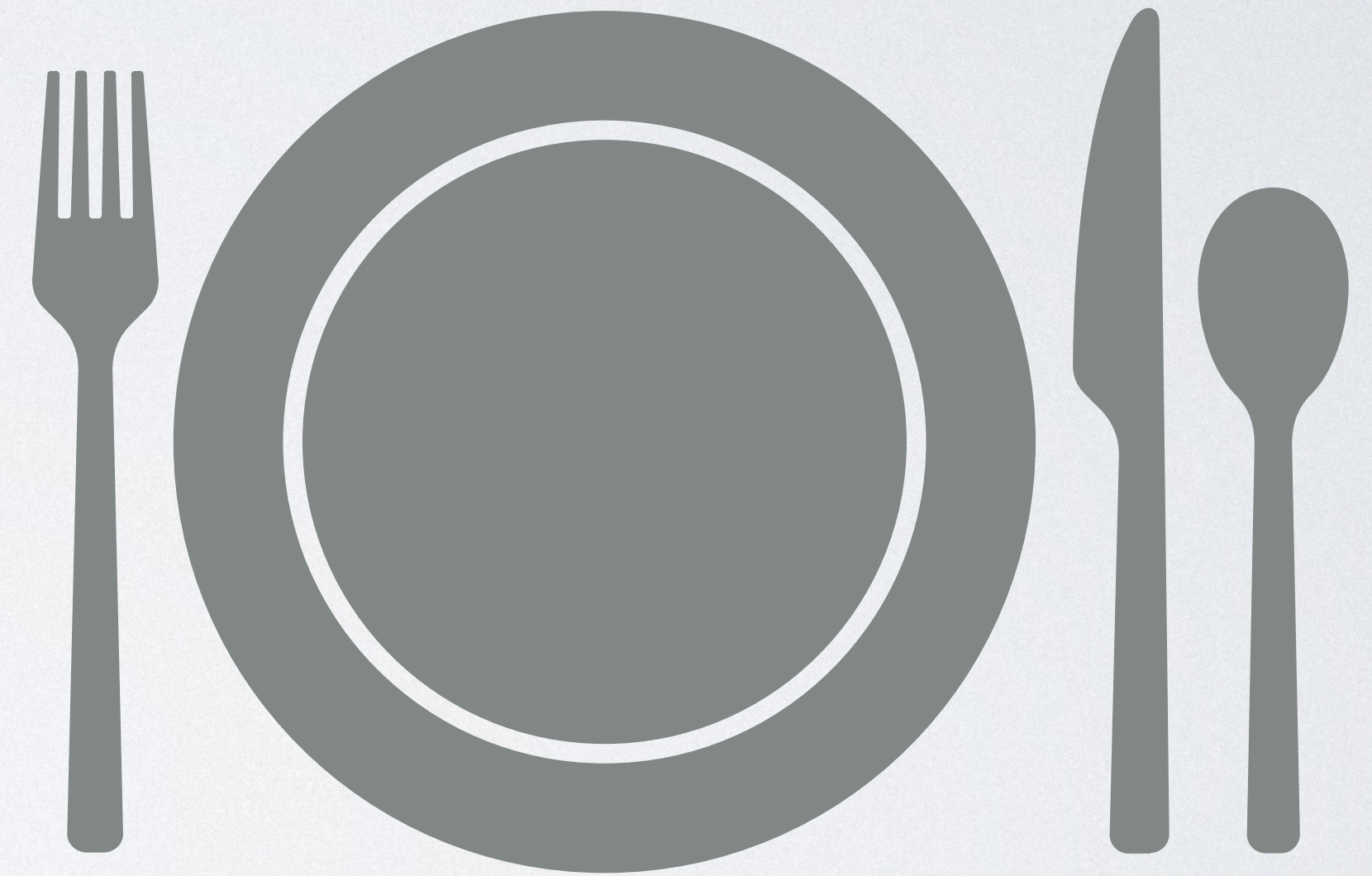

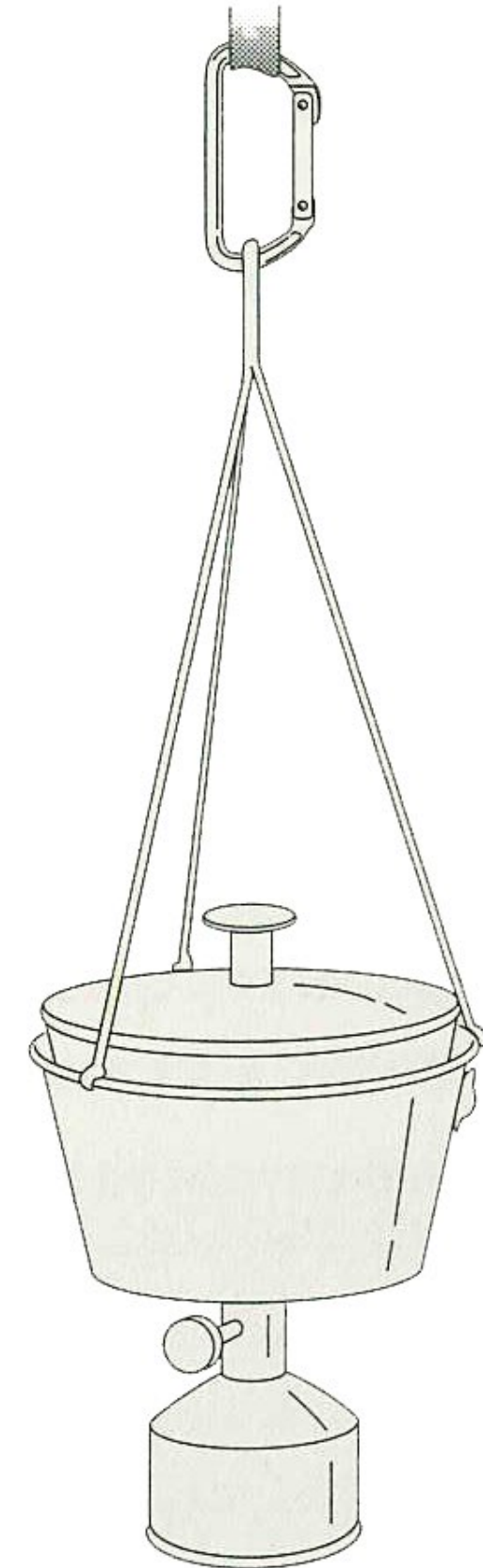
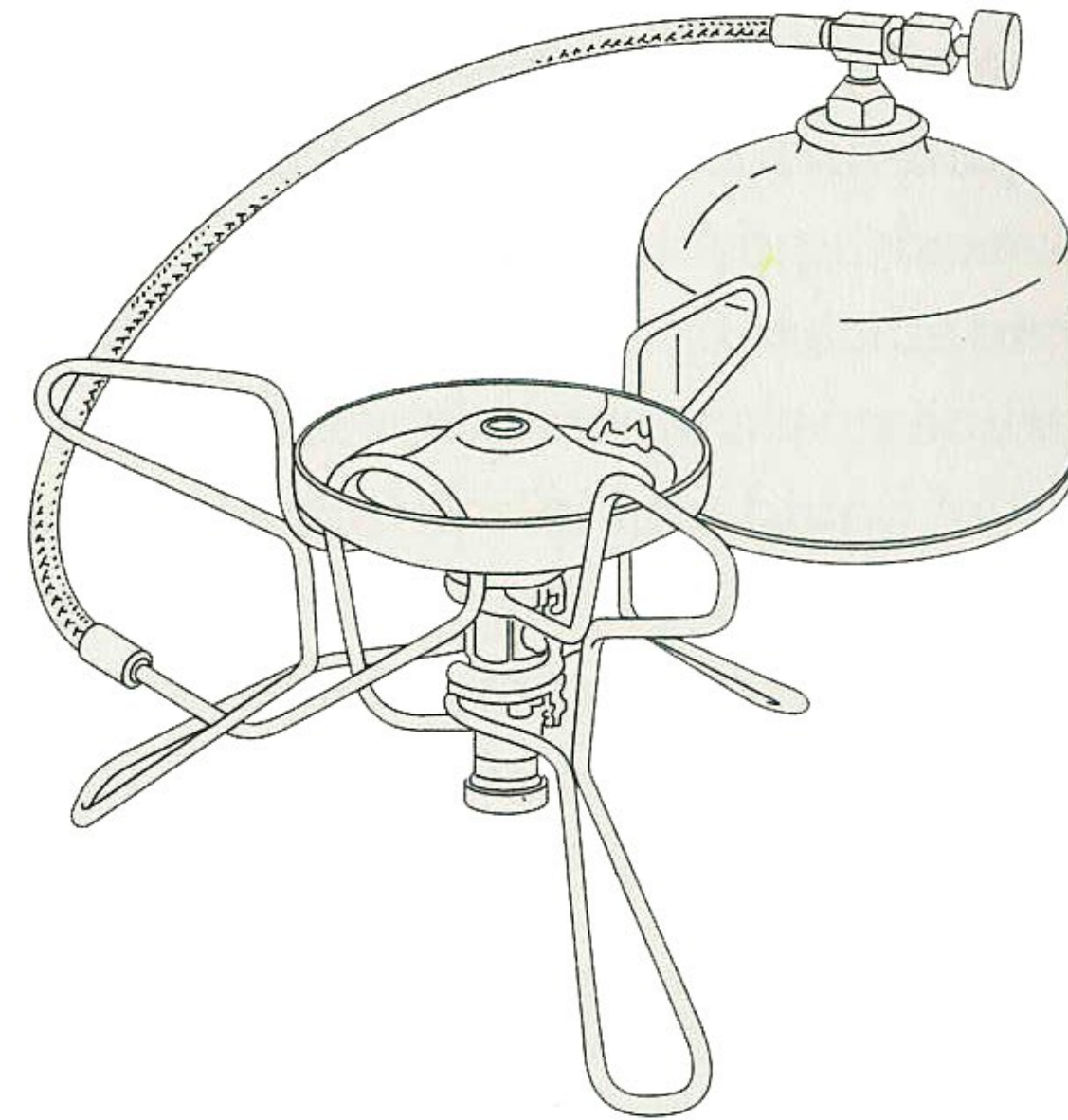
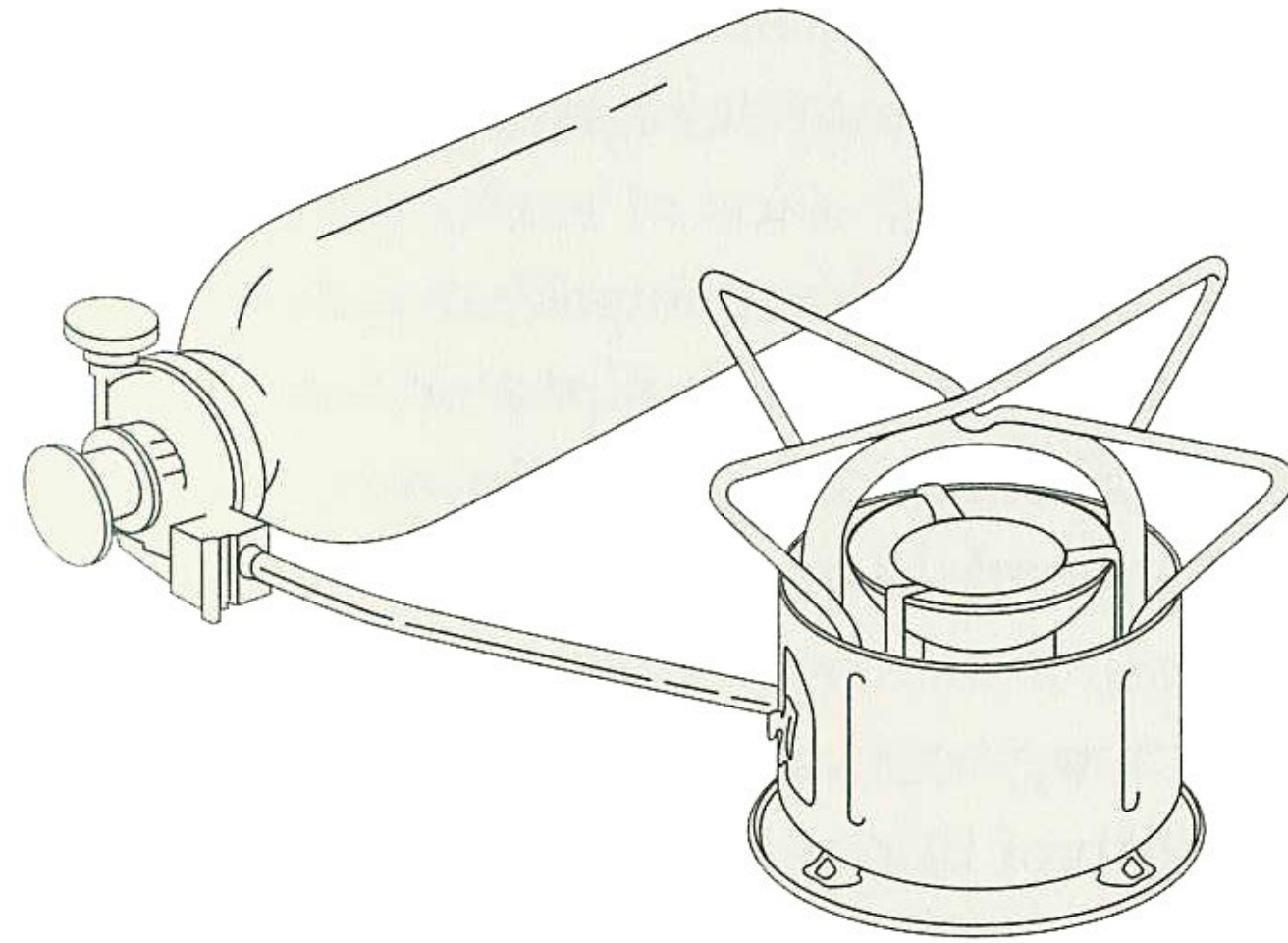
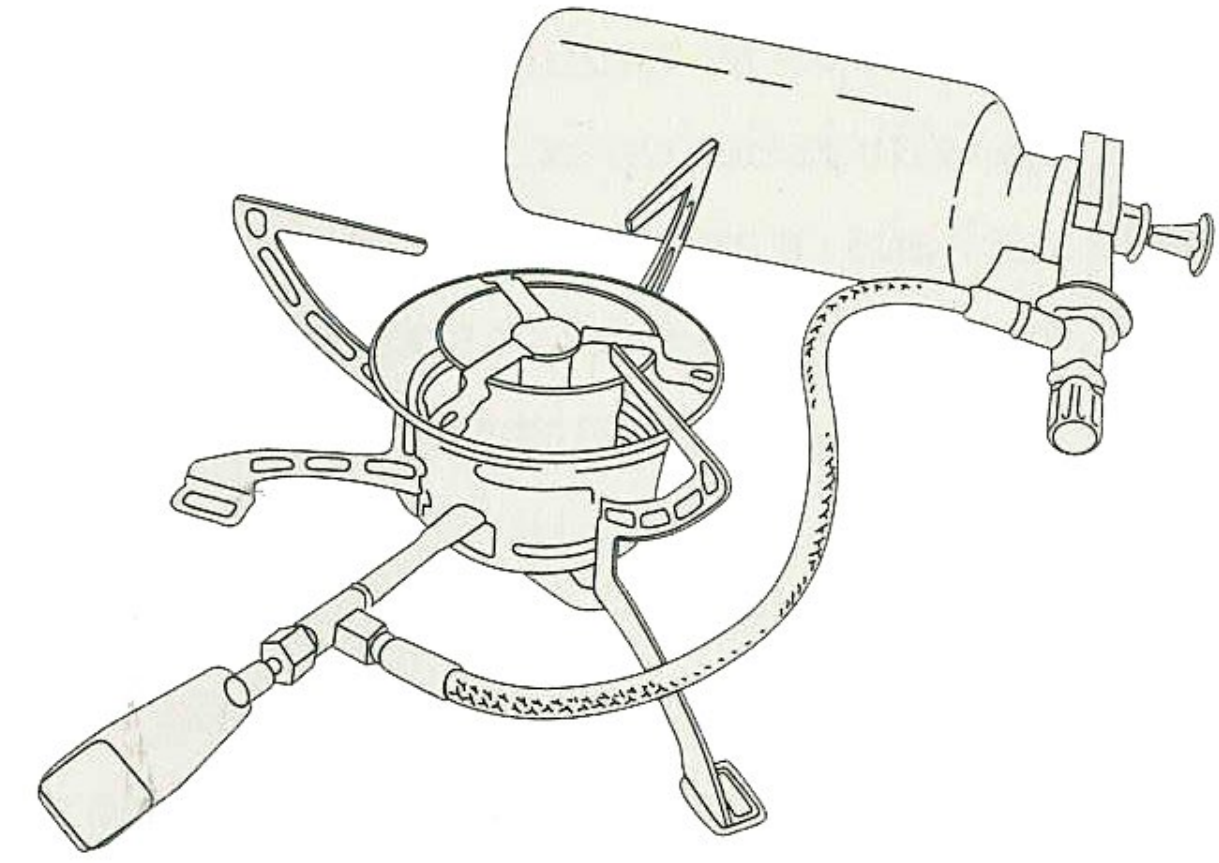
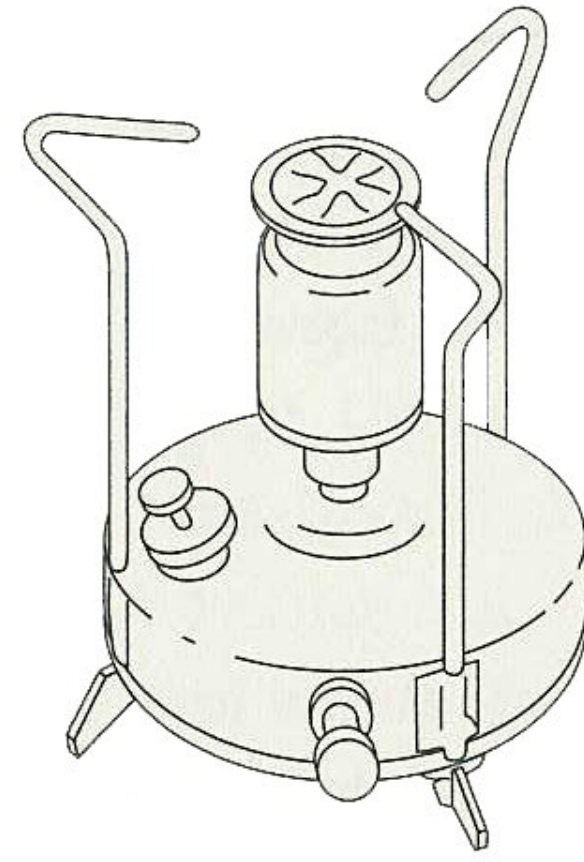
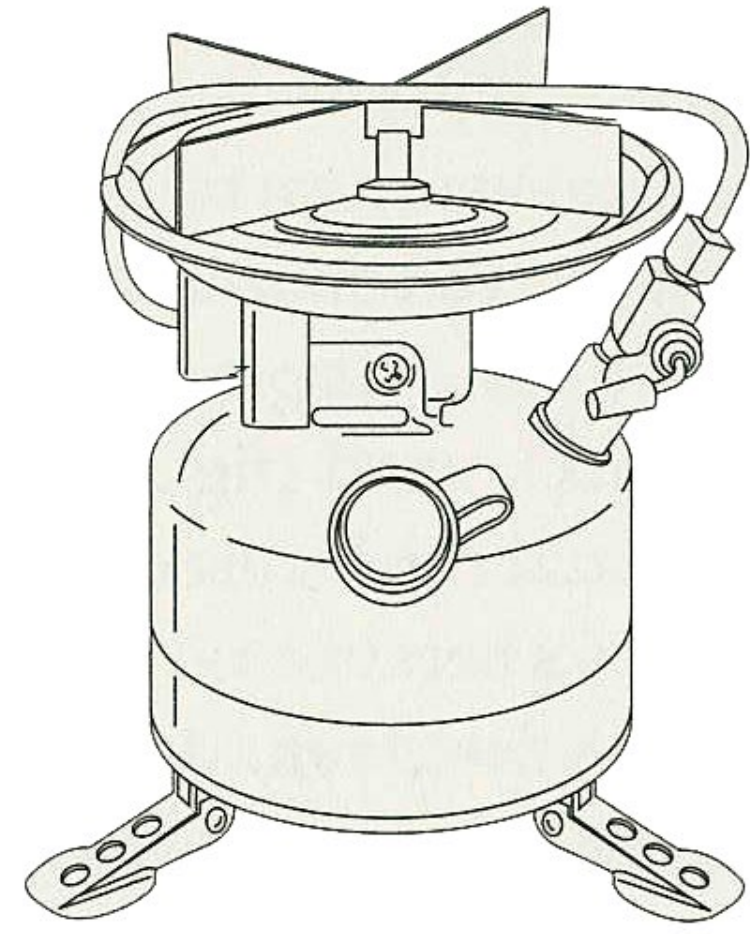
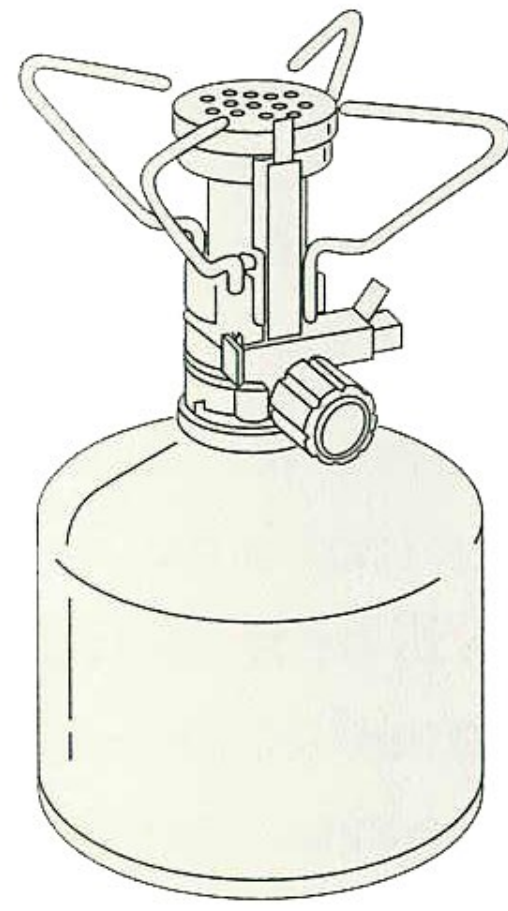

住

- 帳篷：三季帳、四季帳、天幕帳
- 睡墊：充氣睡墊、泡綿睡墊、行軍床
- 睡袋：化纖睡袋、羽絨睡袋
- 防潮布：化纖防潮布、鋁箔防潮布



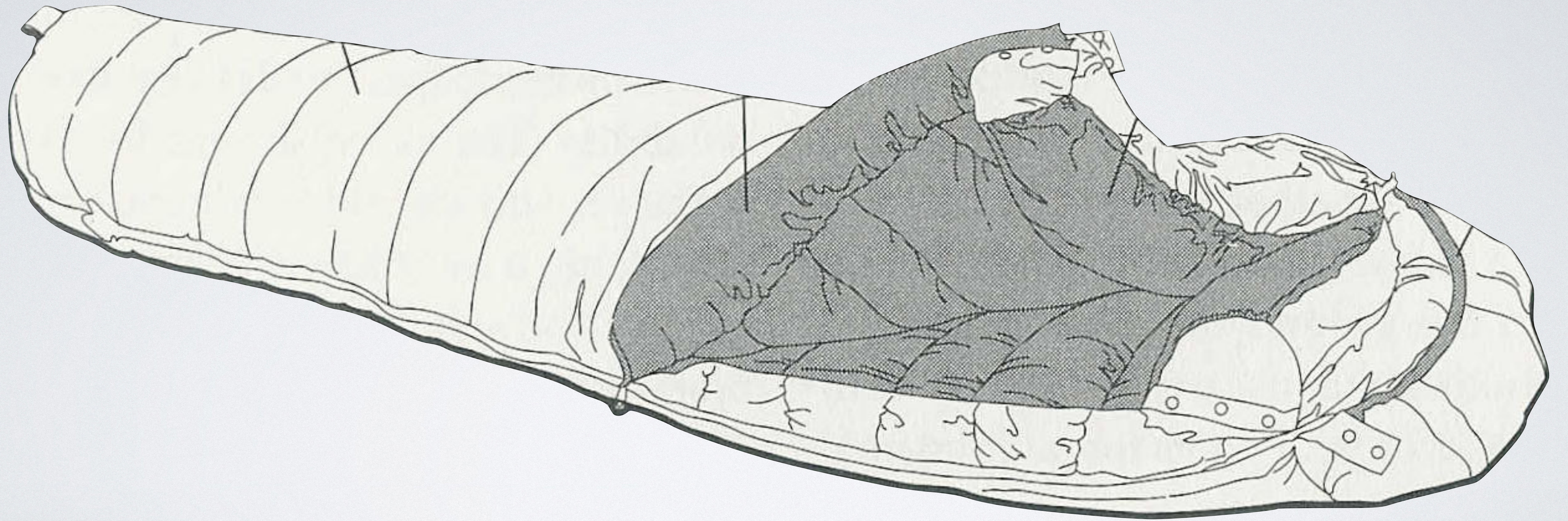

行

- 襪子：內襪、外襪、防水襪
- 鞋子：低筒、中筒、高筒、涼（拖）鞋
- 登山杖
- 導航工具：地圖、指北針、GPS
- 照明：頭燈、手電筒、緊急照明燈、信號燈
- 背包：大背包、小背包



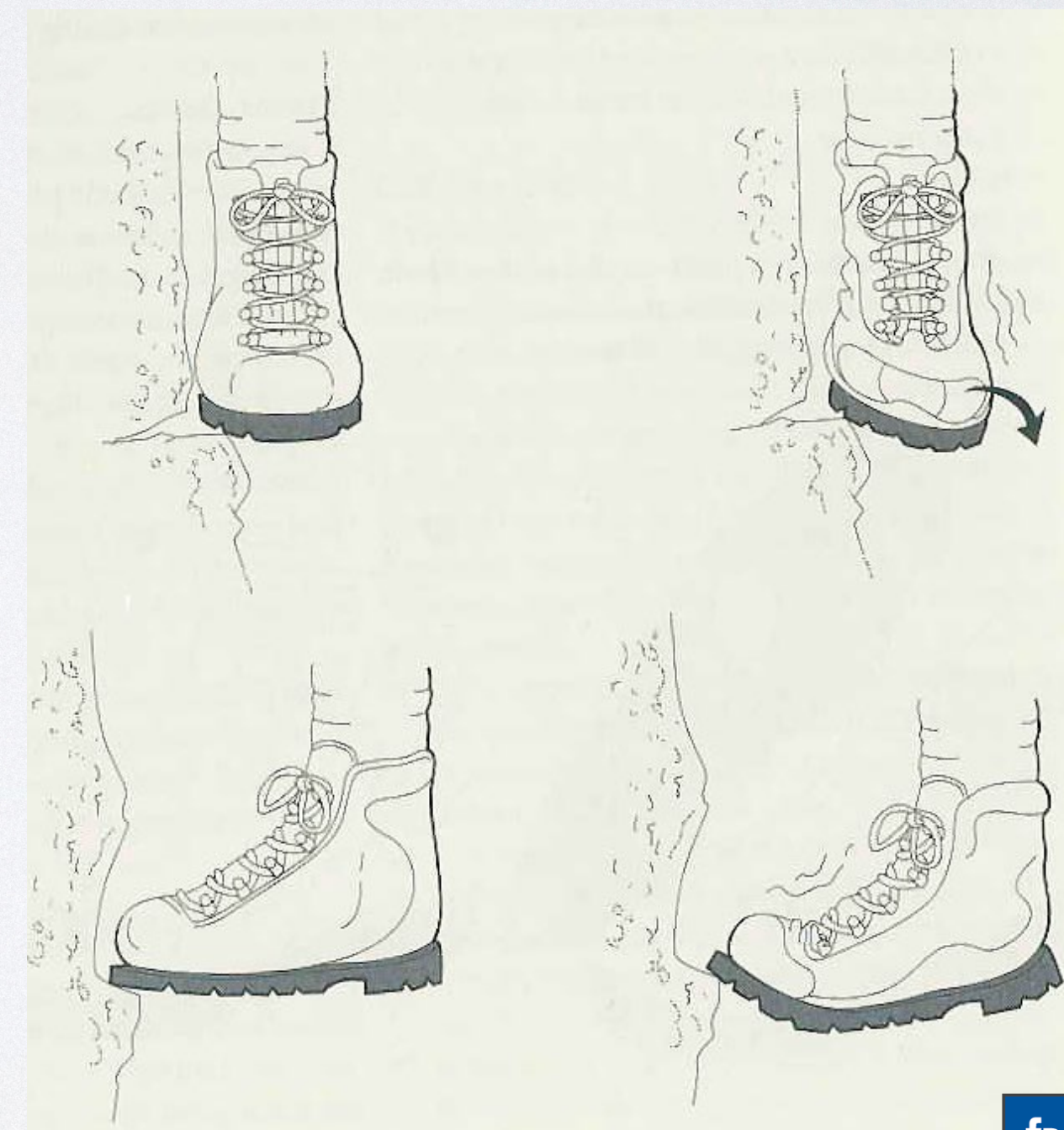
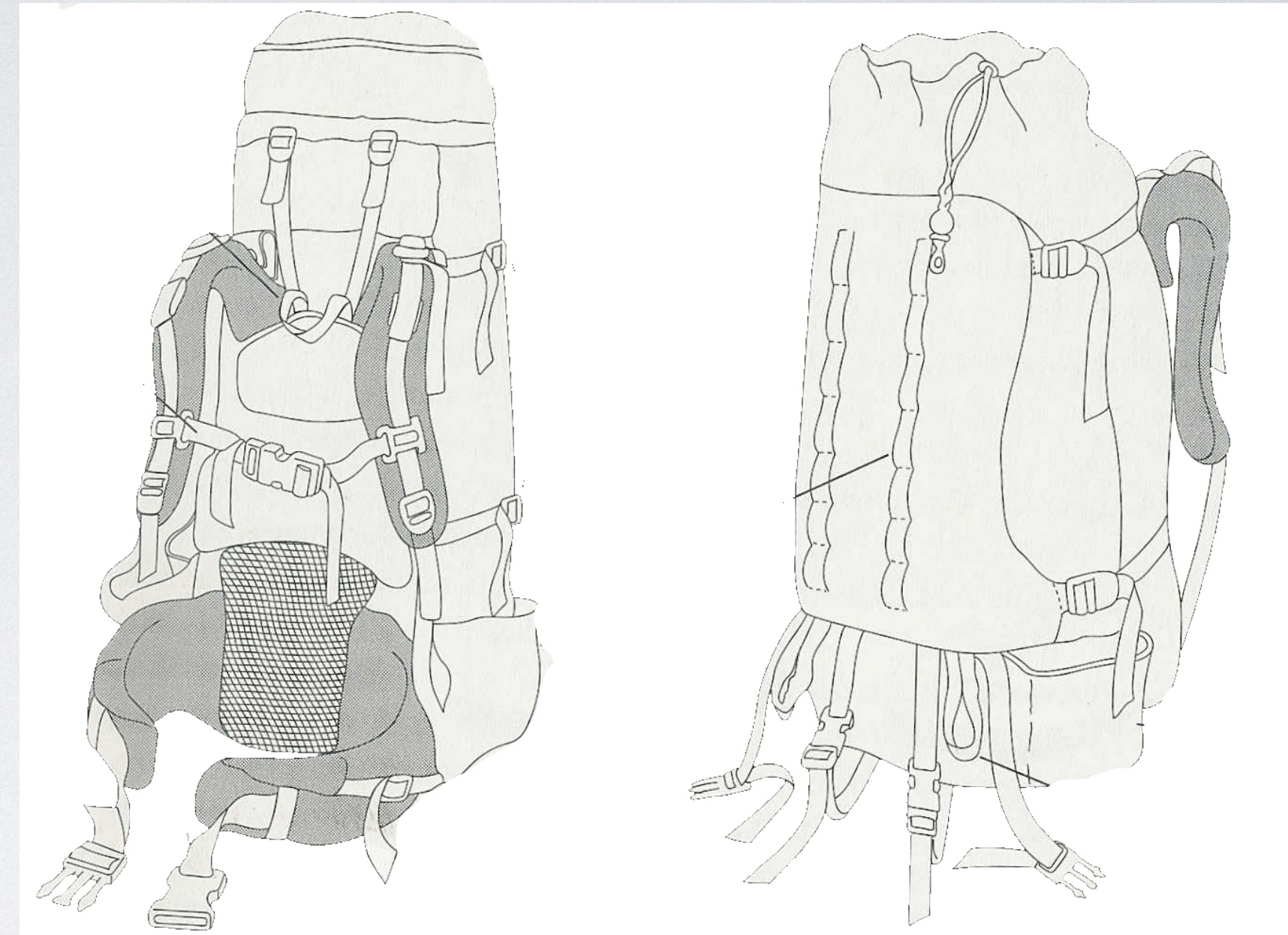

育樂

- 工具：工具鉗、刀子、瑞士刀、鏟子
- 急救包：創傷急救包、腳部護理包



緊急處置類

Airway: NPA, OPA, 抽吸器、別針
Breathing: 氧氣治療設備、甦醒球、吹氣面膜

Circulation: 紗布、繃帶、三角巾、止血帶、網繃、紙膠帶、生理食鹽水、靜脈注射組、優碘、Opsite

Disability: 頸圈、長背板、KED

Exposure: 骨折固定護木、剪刀

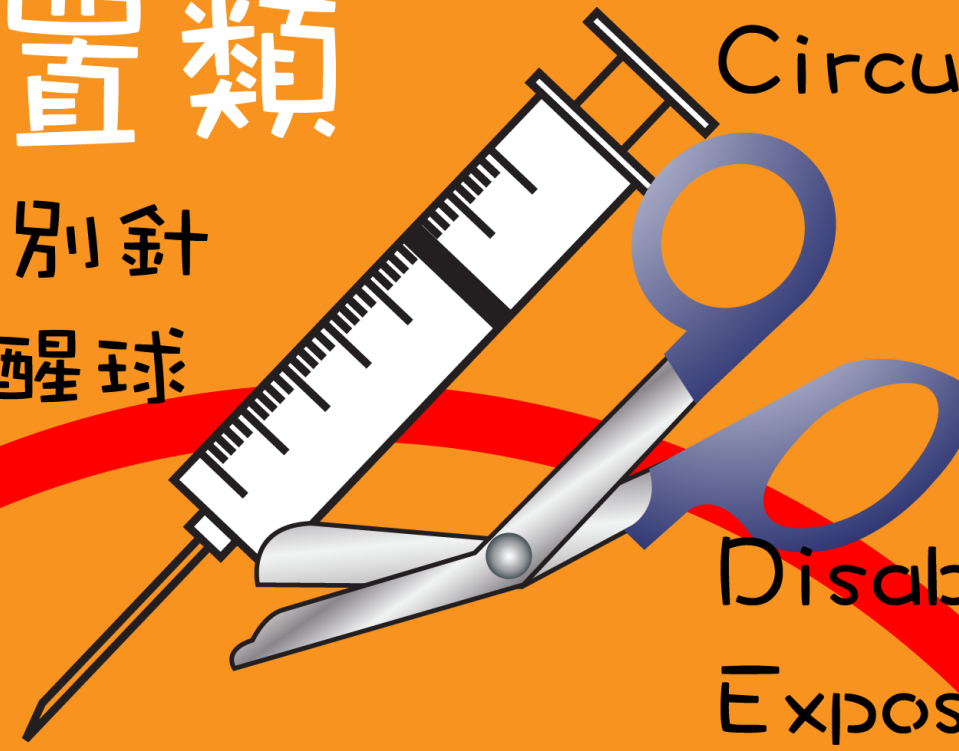

急救包

檢查評估類

瞳孔筆、血壓計、血氧機、聽診器、溫度計、血糖機、尺



感染控制類

手套、口罩、護目鏡、隔離服、感染垃圾袋

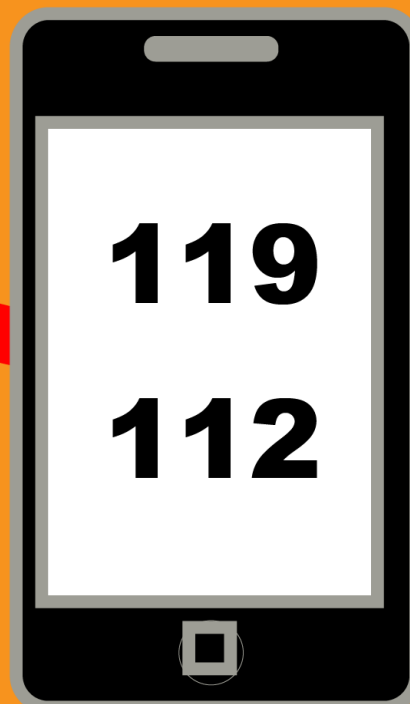

哨子、反光板、燈、無線電、筆、記錄表

通訊紀錄類

雜誌類



總結

- 沒有最好的裝備，只有最合適的裝備
- 乾、爽、濕、冷
- 十項必需品是保命的物品，其他的戶外裝備都是在增加戶外活動的舒適度



facebook

戶外安全對策本部



結繩技士訂購